

Allow for maintaining safe access to the cemetery for visitors during the course of the work.

Carefully remove existing gates and store on site.

Demolish existing gate piers, reclaiming hinges if possible and make good to ground level.

New piers to be 450x450mm in brickwork, with cant brick detail as shown, built up off 1:3:6 mix. concrete foundation.

Concrete fill to cavity of pier

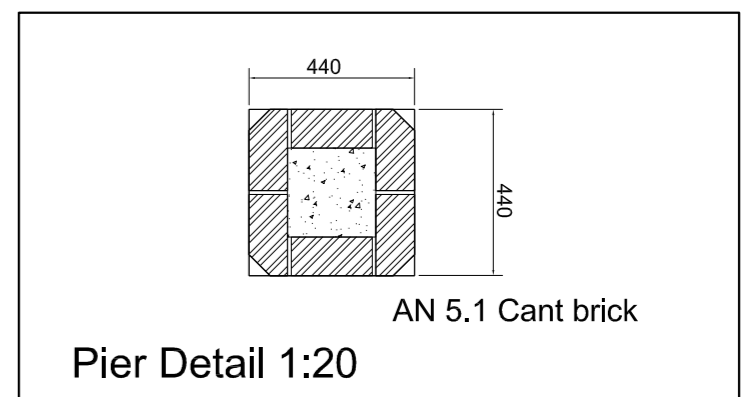

Rev	Date	Description

**Alterations to Access
Cornard Cemetery**

Scale	1:100 & 1:50	Size	A2	Title	Proposed Plan
Drawing No.	A213 02	Date			November 2007

DLDesign Services
 10 Gowers End
 Glemsford, Sudbury
 Suffolk CO10 7UF
 Tel. No. 07967 611105
 Email. dlds@dldesignservices.net

 CAD Drawing Services

This Drawing is Copyright DO NOT SCALE Verify all information on site

Note: Dimensions shown are for pricing purposes only and all information must be confirmed on site at the commencement of the works